

Drop Down Loft Door - Insulated to Part L Regulations

CODE **GL250-03L (EPS)**

Description

The GL250-03L (EPS) Part L Drop Down Loft Access Door provides an unobtrusive and cost effective alternative to traditional loft space access. The door has a twist action, three point closing mechanism along with a unique hinge system, allowing the door to be hinged down or be removed from the frame completely for unobstructed access into the roof space.

Draught seals are located to seal between both the frame and the ceiling and the door and the frame. These prevent the problem of moist warm air entering the roof space and meet the requirements of Part L of the building regulations. The product is also supplied with 110mm of expanded polystyrene insulation to provide a U-Value of 0.35W/m²K as outlined in the Robust Construct Details.

The door and frame is stylish yet unobtrusive which has been designed to fit in with almost all house decor styles. With a lightly textured white finish the door can be easily cleaned with a solvent free damp cloth, or alternatively the GL250-03L (EPS) can be painted to match the décor.

The door catch can be operated by hand or with a pole by using the pole attachment located in the insulation on the back of the door (pole not supplied). The door can also be used with the GLL256 and GLL257 loft ladders, the catch can be easily operated with the loft ladder pole.

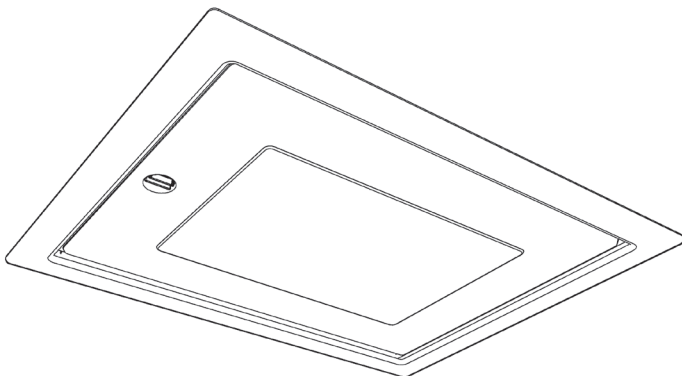

Product Specifications

Colour	White
Packing Details	Individually packaged in a polythene bag and cardboard box
Box Weight	4.4 kg
Material	High Impact Polystyrene
Manufacturing Process	Injection Moulded
Draught Seals	Expanded Polyurethane
Insulation	110mm Expanded Polytyrene
U-Value	0.35 W/m ² k

Environmental & Air Leakage Assessment

The expanded polystyrene insulation used in the GL250-03L (EPS) has a Global Warming Potential (GWP) of less than 5 and is CFC/HCFC-free with an Ozone Depletion Potential (ODP) of zero

The GL250-03L (EPS) loft access door has been independently air leakage tested by the BRE to the requirements for a "Well Sealed Ceiling" as outlined in BS 5250, meeting the recommend leakage rate of <1m³ at a pressure differential of 2 Pa, and the Building Regulations Part L2A 'reasonable limit' for the design air permeability of buildings of 10m³/h.m² at 50Pa.

References

BRE: Digest 262
 BSI: BS5250
 DOE: Building regs L1
 NHBC: Good Practice Guide
 NHBC: Standards 7.2
 DEFRA: Robust Details 8.04

MANTHORPE BUILDING PRODUCTS LTD
 MANTHORPE HOUSE
 BRITTAIN DRIVE
 CODNOR GATE BUSINESS PARK
 RIPLEY
 DERBYSHIRE DE5 3ND

TEL: 01773 303 000
 FAX: 01773 303 300
 EMAIL: mbp.care@manthorpebp.co.uk
 WEB
 www.manthorpebp.co.uk

DRN B.H. Date 26.06.19
 The company maintains a policy of continuous development of its product range and reserves the right to amend the specification without notice.

DRG No
MBP 8192

Issue
C
 1 of 2

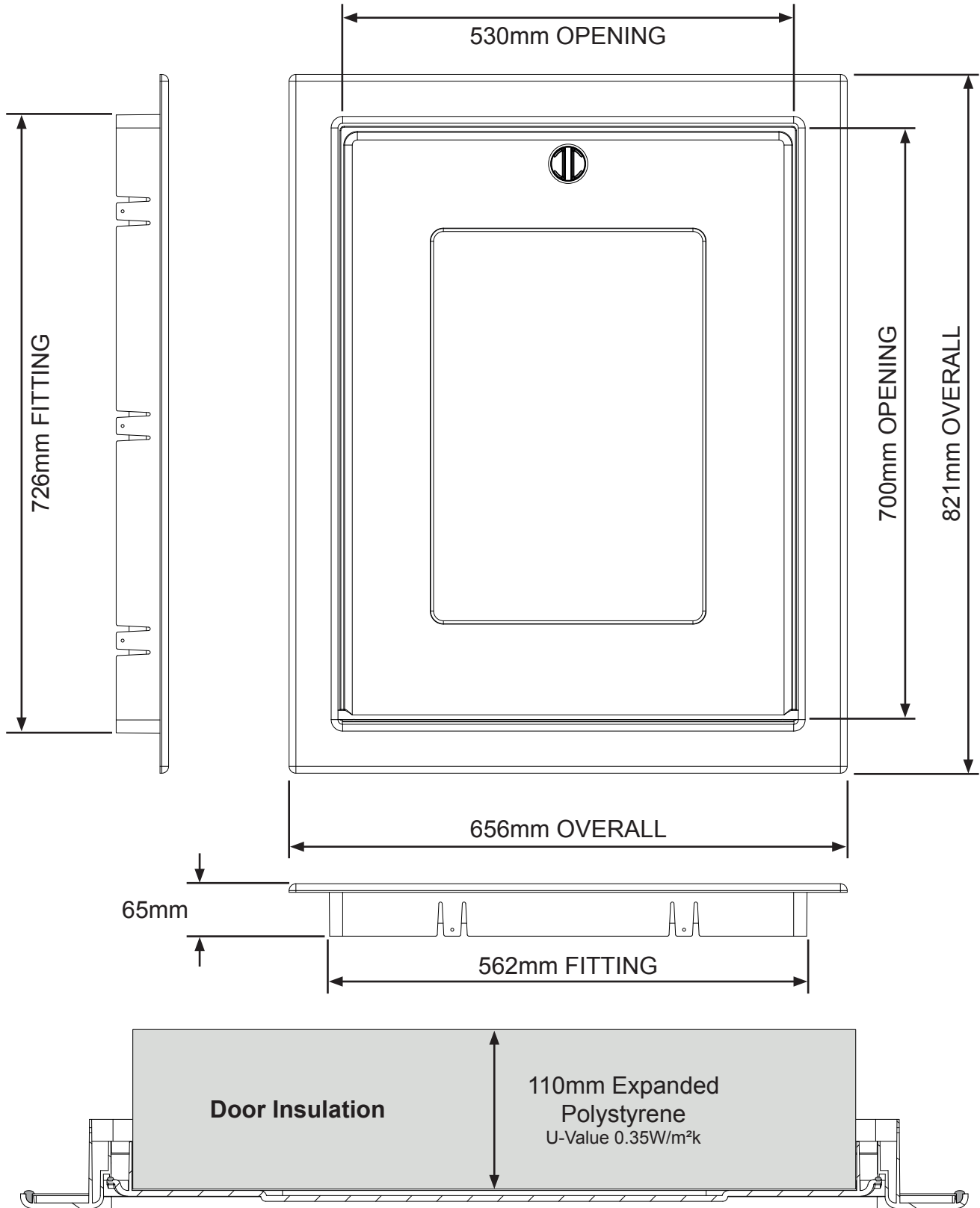

MANTHORPE BUILDING PRODUCTS LTD
 MANTHORPE HOUSE
 BRITTAIN DRIVE
 CODNOR GATE BUSINESS PARK
 RIPLEY
 DERBYSHIRE DE5 3ND

TEL: 01773 303 000
 FAX: 01773 303 300
 EMAIL: mbp.care@manthorpebp.co.uk
 WEB: www.manthorpebp.co.uk

DRN B.H.

Date 26.06.19

DRG No

MBP 8192

Issue

C

2 of 2

The company maintains a policy of continuous development of its product range and reserves the right to amend the specification without notice.