

Dry Ridge Tile

CODE GDR-T / -INC.SC

Product Preparation

Important:

Before installation of the GDR-T Dry Ridge Tile ensure that each tile is a fully assembled unit with 2 sets of overlapping comb skirts. Fig.1 shows an exploded view of the whole assembly.

With the top batten secured, place the first plastic ridge tile flush with the end of the verge and secure with the screws provided (See Fig.2). Repeat this process along the length of the ridge, ensuring all tiles are locked together and finish the ends with a Manthorpe Ridge End Cap.

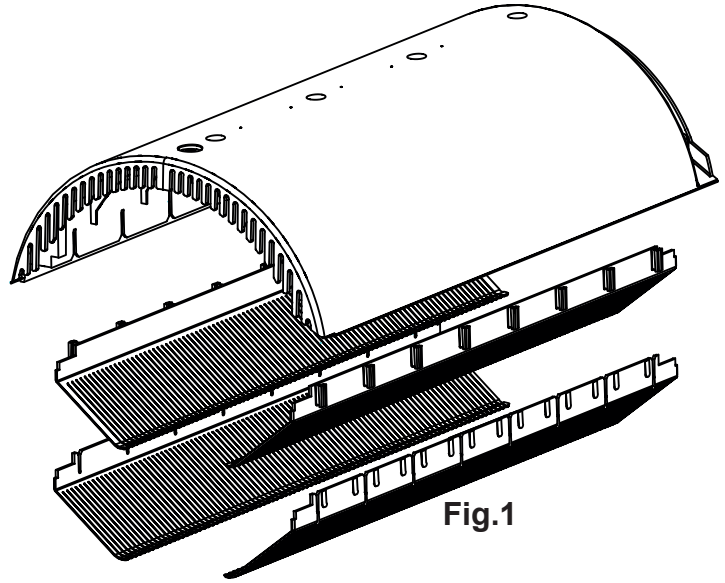

Fig.1

Description

The Manthorpe Dry Ridge Tile System is designed to replace the more traditional Clay and Concrete Ridge tiles with a UPVC plastic moulded part. Being easier and faster to fit than existing systems, it is aimed at the refurbishment and new build markets. The latest addition to the Manthorpe Dry Fix product family, the Dry Ridge Tile requires no wet trade and can be easily fitted by one person using the pre drilled screw fixings. The double comb design prevents entry of wind driven rain, birds and large insects into the cavity space but still allows the 5000mm²/m ventilation into the roof space at ridge level. The textured concrete finish available in grey, dark brown and terracotta.

Fitting

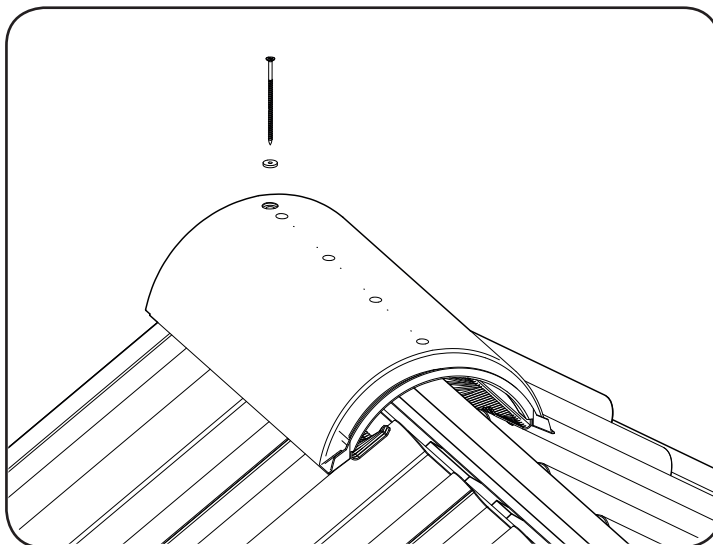

Fig.2

References

BSI: British Standard 5534:2003
BSI: British Standard 6399-2:1997
NHBC Standards Chapter 7.2

Specification

| | |
|-----------------------------------|--|
| Colours - Ridge Tile | Grey Dark Brown Terracotta |
| Packing Details | GDR-T Box of 10 inc. 11 screws and washers GDR-T-INC.SC Box of 10 inc. 11 screws & washers & 10 GDR-SC Batten Saddle Clamps |
| Weight | 1.148 kg |
| Materials (Ridge Tile) (Combs) | UPVC LDPE |
| Manufacturing process | Injection moulded |

MANTHORPE BUILDING PRODUCTS LTD
MANTHORPE HOUSE
BRITAIN DRIVE
CODNOR GATE BUSINESS PARK
RIPLEY
DERBYSHIRE DE5 3ND

TEL: 01773 303 000
FAX: 01773 303 300
EMAIL:
mbp.care@manthorpebp.co.uk
WEB
www.manthorpebp.co.uk

DRN B.H. Date 26.06.19

The company maintains a policy of continuous development of its product range and reserves the right to amend the specification without notice.

DRG No
MBP 8272
PAGE (1 OF 2)

Issue

C

Dry Ridge Tile

CODE GDR-T / -INC.SC

TILE DETAILS

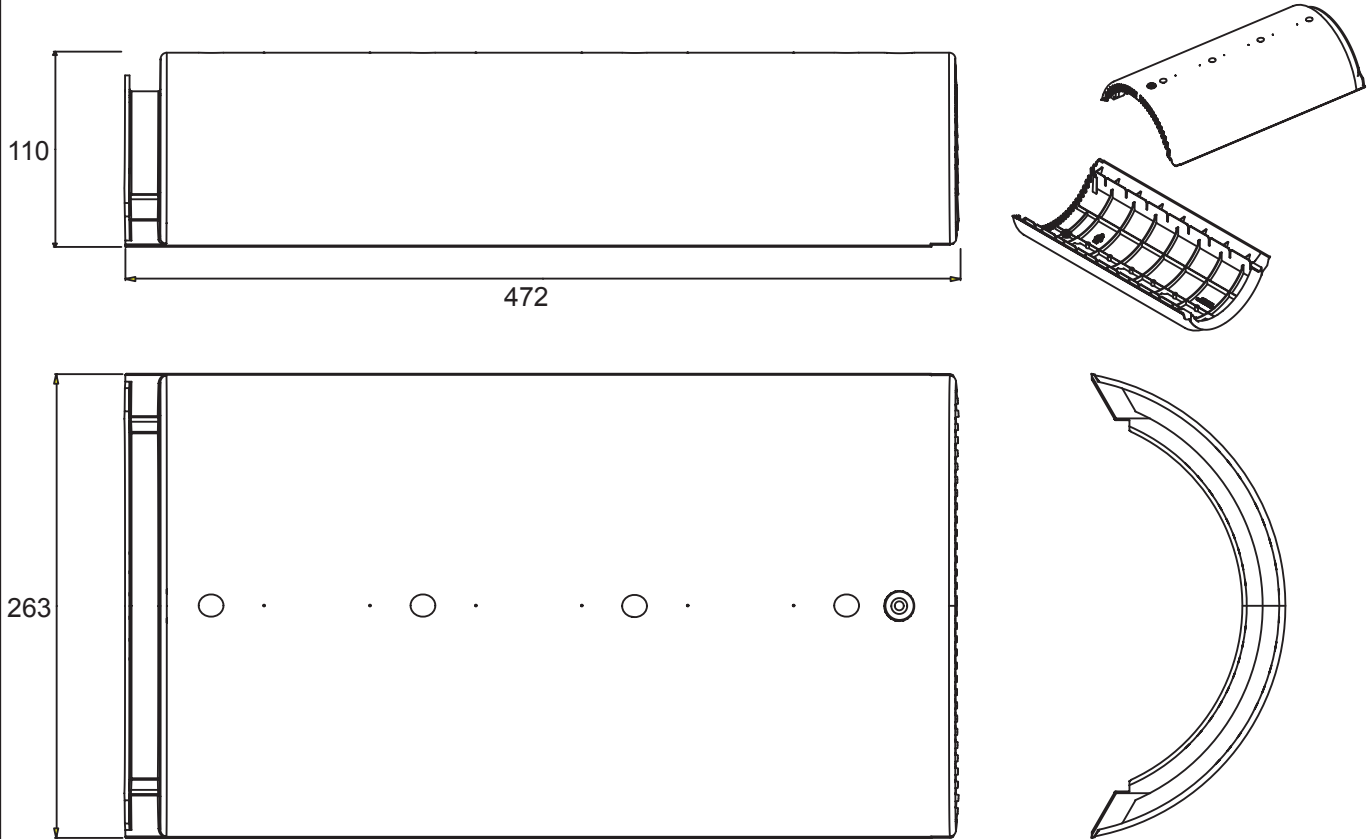

COMB DETAILS

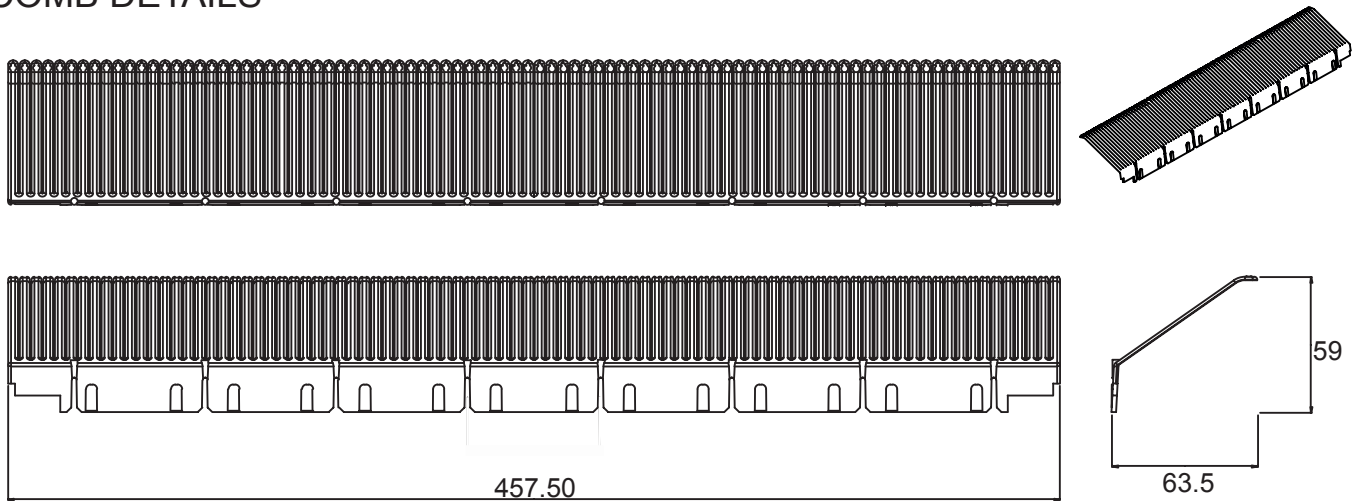

NOTE: This product should not be installed within close proximity to potentially hot elements of the roof structure, such as chimney pots or flue outlets, or on a roof surface which could reach excessively high temperatures, such as metal clad or glazed roofs.

| | | | | | |
|--|--|---|---------------|--|----------|
| MANTHORPE BUILDING PRODUCTS LTD MANTHORPE HOUSE BRITAIN DRIVE CODNOR GATE BUSINESS PARK RIPLEY DERBYSHIRE DE5 3ND | TEL: 01773 303 000 FAX: 01773 303 300 EMAIL: mbp.care@manthorpebp.co.uk WEB www.manthorpebp.co.uk | DRN B.H | Date 26.06.19 | DRG No MBP 8272 (PAGE 2 OF 2) | Issue |
| | | The company maintains a policy of continuous development of its product range and reserves the right to amend the specification without notice. | | | C |