

# Manthorpe

## SmartVerge™

Polypropylene

# Linear Dry Verge System

## Fitting Instructions

MBP\_GU\_1330\_01

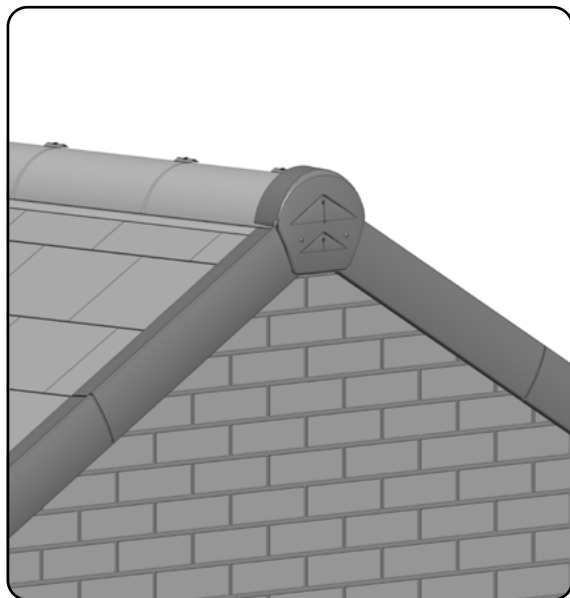

## BS 8612 Information

**Independently tested  
to conform with the  
requirements of the  
BS 8612 standard.**

**Performance data for  
the tests conducted on  
this product is available  
upon request.**

### Manthorpe Building Products Limited

Manthorpe House, Brittain Drive, Codnor Gate Business Park, Ripley, Derbyshire DE5 3ND  
T: (01773) 303 000 F: (01773) 303 300 E: [mbp.care@manthorpe.co.uk](mailto:mbp.care@manthorpe.co.uk)  
W: [www.manthorpebp.co.uk](http://www.manthorpebp.co.uk)



# Installation

**NOTE** The mounting face of the timber, to which the verge units are fixed, should overhang the finished face of the gable wall or bargeboard by at least **30mm**.

## Mounting Option A - Counter Batten Fixing

Run a counter batten up the length of the verge allowing at least **30mm** overhang from the face of the batten over the wall or bargeboard. This batten should be securely fixed to tiling battens, bargeboard or wall, the specific fixing method will depend on the detail. Continue this on both sides of the roof running from the eaves to the ridge. This is used for fixing each Linear Verge Unit to the verge of the roof.

See installation step 4 for recommended fixings.

## Mounting Option B - End of Batten Fixing

Alternatively, each unit can be fixed to the ends of the tiling battens. Saw the tiling battens off square so that they overhang the gable wall or bargeboard by at least **30mm**. Each verge unit will have to be shortened for the nail holes to align with the batten ends, cut each unit square using a fine tooth saw.

Securing a verge unit into the batten end can be achieved with either a nail or screw fixing, however to meet the British Standards, a Batten End Clip (GDV-BEC) must be used when fixing into the end grain of a tiling batten with a nail.

To install the Batten End Clip, place one clip centrally about each tiling batten, ensuring the mounting face is square against the cut end. Fix the clip in position through the two top holes using 25 x 3.35mm aluminium clout nails.

1. Using a suitable stainless steel fixing, securely mount a **GLV-FC Fixing Clip** to the end of the counter batten at the eaves. It is important to ensure that the flange of the fixing clip that is labelled "top" faces upwards.

For straight verge runs continue to step 4.

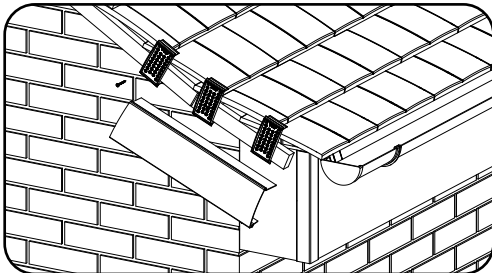

2. For roofs with a change in pitch at the eaves, use three Fixing Clips as shown. Saw a length of the Linear Verge Unit down to cover the full length of the tilted section of the verge. Hook the shortened Linear Verge Unit section under the bottom of both Fixing Clips and then push it on to the verge until it engages with both clips.

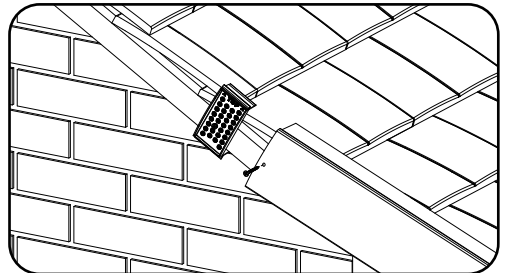
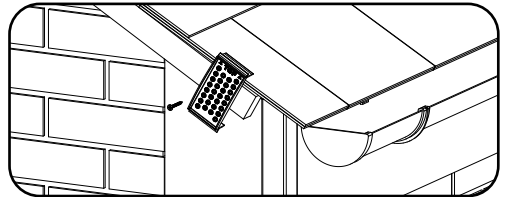
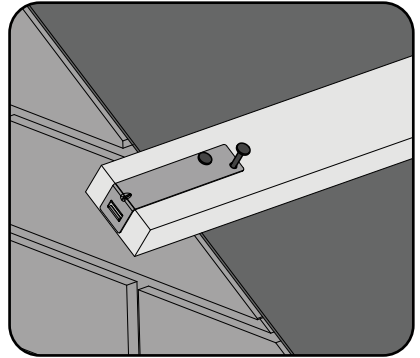
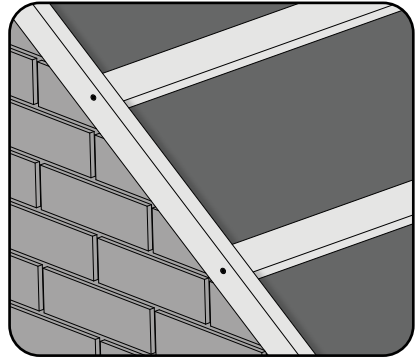

3. To prevent the shortened Linear Verge Unit from sliding down the verge, drill and fix a screw **10mm** from the edge into the batten as shown above.

Proceed to fit the straight run of verge as detailed from step 4 onwards. Detail on how to mask the join at the change of pitch is shown in step 6.

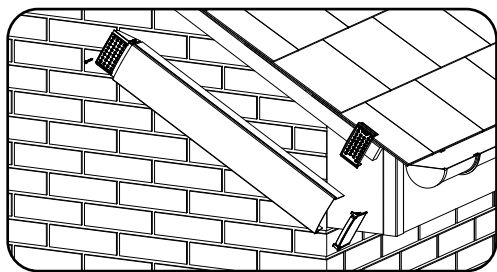

**4.** Hook the **Linear Verge Unit** under the bottom of the Fixing Clip and press firmly until it engages. While pressing the verge unit down against the tiles, fix the head end of the linear verge unit through an appropriate hole using a stainless steel fixing; either a 3.35mm x 38mm annular/spiral bound shank nail or a no.8 x 38mm pan head woodscrew.

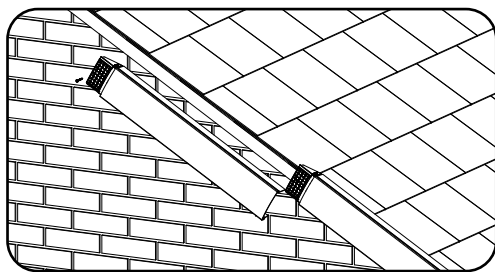

**5.** Continue on up the run of the verge, clipping and fixing each Linear Verge Unit consecutively at the toe and head to ensure a secure fit.

Leave an expansion gap between each Linear Verge Unit of **at least 4mm** to allow for expansion of the product in warmer temperatures. There is a line to denote the position.

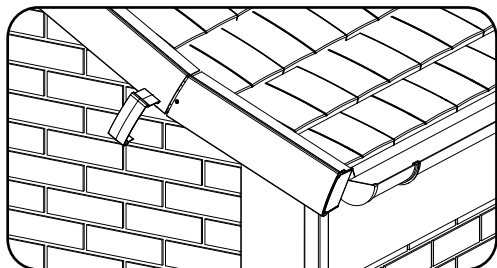

**6.** For roofs where the bottom course of tiles are tilted upwards, cover the fixing and joint using a **GLV-VU Verge Union**.

Hook the Verge Union around the top flange between the Linear Verge Unit and the tiles, then firmly push the Verge Union onto the joint until the clip engages with both Linear Verge Units.

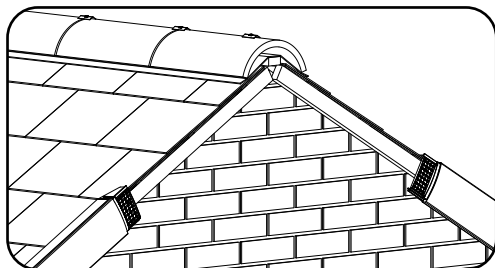

**7.** Continue to fit full lengths of the linear units up the run of the verge until all tiles have been covered or no full lengths can be fitted as shown.

Once one hand of the verge is completed repeat steps **1** to **6** on the opposing verge, this time using the other hand of Linear Verge Units.

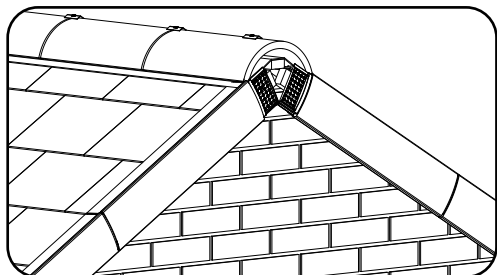

**8.** At the apex, shorten the last two units as shown above to fit the remainder of the verge.

To shorten the Linear Verge Units, measure and saw each unit square using a hacksaw or fine tooth saw then deburr with a scraper.

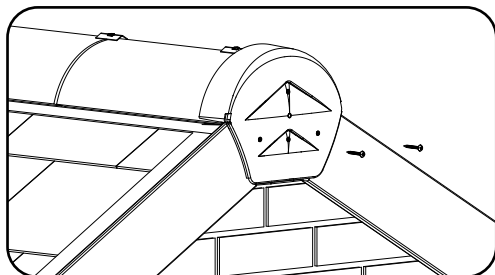

**9.** Align the Ridge End Cap with the top two verges and flex it over the units and the top of the ridge tile. Cut the lower tabs if needed to fit to main unit and pitch. Using the screws provided, fix the end cap in place into the end of the ridge batten, top tiling/mounting battens, barge board or masonry.

# The Complete SmartVerge™ Linear Dry Verge Range

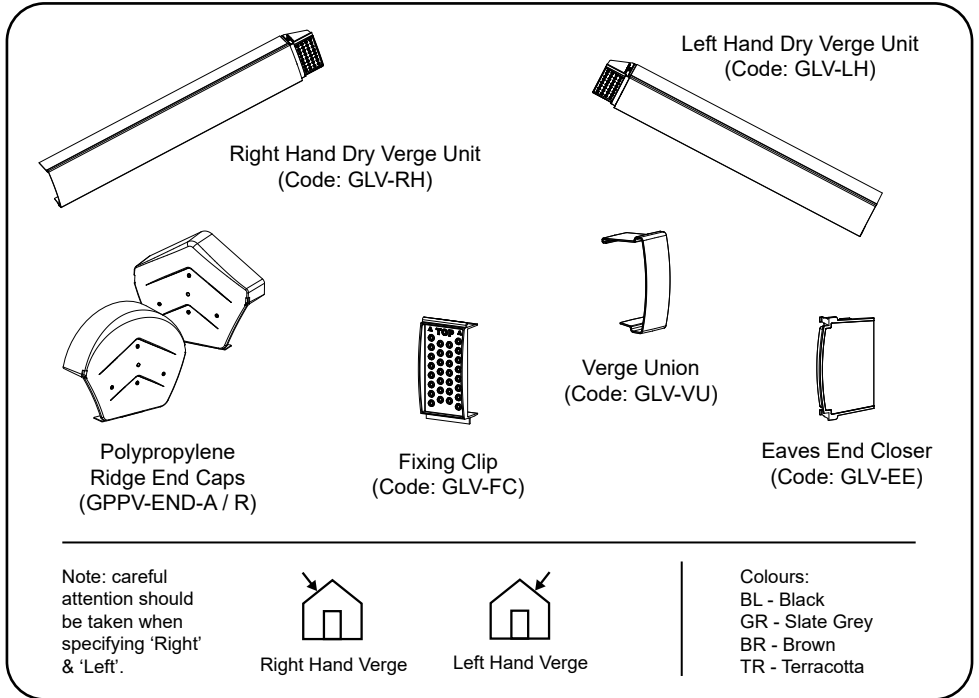

## Typical Verge Details

**Fig A. Flush Verge Detail**

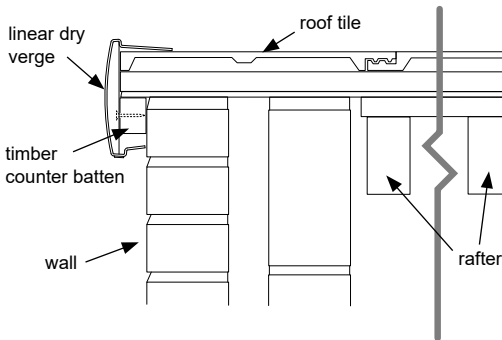

**Fig B. Overhanging Verge Detail**

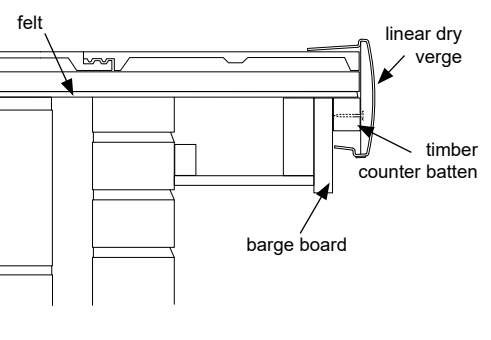

## Compatibility

The SmartVerge® Linear Dry Verge System is compatible with most Fibre Cement Slates, Natural Slates and Interlocking Plain Tiles. The Linear Verge units will also fit over a verge detail if the maximum depth does not exceed 100mm, this depth will include the roof covering at its largest thickness at the overlap, any undercloak construction and the fixing batten strip. For a full list of compatible tile and slate profiles, visit [www.manthorpebp.co.uk](http://www.manthorpebp.co.uk).